

ROLLING GRILLES

VISIONAIRE® MICROCOIL® GRILLE

CLOPAY COMMERCIAL – MODELS CESG10C, CESG12C



Model CESG10C Door

SECURITY. VISIBILITY. ALL IN ONE COMPACT GRILLE SOLUTION

LESS HEADROOM, MORE SPACE

The Visionaire® MicroCoil® Grille requires nearly 30% less headroom than any other standard grille in the industry, thanks to its reduced coil size. With headroom requirements as little as 15.5" as compared to a standard rolling grille headroom of 24", this low headroom grille is ideal in retail, city storefront, historic buildings, schools, with any structure that cannot be heavily altered, or where space is an issue.

Standard rolling grille requires 24" headroom



Visionaire MicroCoil requires 15.5" headroom

clipaycommercial.com

A+ AESTHETICS

Along with being compact, quiet and reliable, the aesthetics of Visionaire® MicroCoil® Grille are uniquely beautiful. Matching the construction of our Extreme® High Performance MicroCoil® Grille with 304 stainless steel links, the sleek profile stands on its own as a design element. Its flexibility offers creativity and the ability to customize curtain patterns in "brick" or "straight" options in aluminum or stainless finishes.

DEPENDABLE SECURITY FOR THE LONG HAUL

Whether motor or manual operation, this lockable grille offers long term, on-demand security. Quiet operation through the patented link construction not only reduces noise and vibration, but also adds to the life of the grille, offering a lifespan of 50,000 cycles. The easy-link repair system is unique to the MicroCoil® Grille and contributes to a lifetime of less maintenance and simple repairs.

ROLLING GRILLES

VISIONAIRE® MICROCOIL® GRILLE

STANDARD COMPONENT MATERIALS AND FINISHES

- 1. SHAFT** – 6" sprung shaft which directly attaches to curtain with accompanying standard grille sensing options.
- 2. CURTAIN** – Self-stacking/nesting lines in mill finish aluminum, 5/16" aluminum rods in mill finish spaced 2.8"–3.9". Aluminum tube spacers on every rod. Links are always made of 304 stainless steel and can be replaced individually or in sections if the grille gets damaged. Grilles are available for opening sizes up to 26' wide × 14' high in aluminum. (26' × 14.5" Max width/height)
- 3. GUIDES** – Extruded aluminum in mill finish with self-lubricating antiwear strips to greatly reduce friction and curtain wear. Includes a fully replaceable UHMW bellmouth.
- 4. BOTTOM BAR** – Heavy-duty extruded aluminum in mill finish with locking.

OPTIONAL MATERIALS AND FINISHES

- Mill Finish
- Aluminum in clear anodized finish
- Stainless steel 300 series in #4 finish
- Hoods available as an option. Galvanized steel with exclusive GalvaNex™ polyester enamel finish in gray or SpectraShield® powder coating in more than 180 colors; aluminum in mill, clear and color anodized finish; or 300 series stainless steel with #4 finish

OPERATION AND STRUCTURAL REQUIREMENTS

Hand-chain and a variety of motor options are available. This product is supported by a guide assembly attached to the jamb construction or structural tubes attached to either wall or overhead construction. No additional header support is required unless hood supports are mandated.

CUSTOM-DESIGNED SOLUTIONS

Contact our experienced Architectural Design Support Team for help in customizing our products to fit your specific application at www.architectdoorhelp.com.

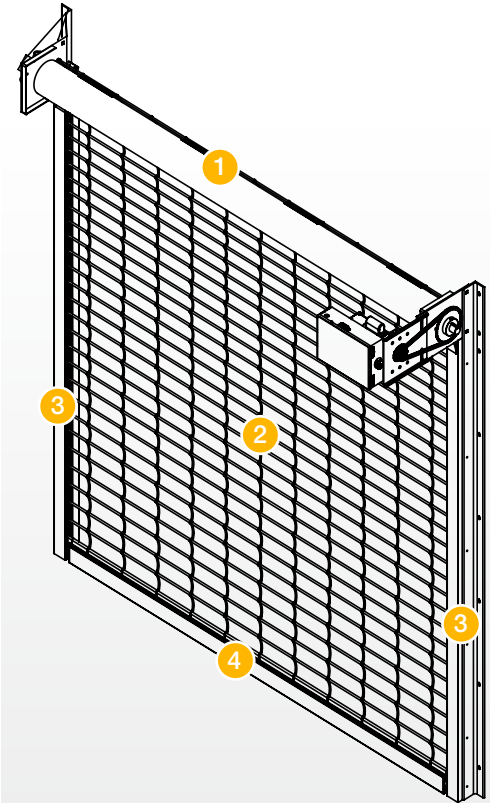

A CHOICE OF CURTAIN PATTERNS

Two different curtain designs provide both visibility and ventilation.

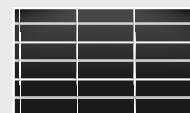

Straight



Brick



For more information on these and other Clipay products, visit clipaycommercial.com. Architects and specifiers, visit architectdoorhelp.com.



©2024 Clipay Corporation. All rights reserved.



CMDC-VNMICROCOILGRILLE-23_REV0924